



#### OFFICE

**Office.** 603 6th floor 298, Beotkkot-ro, Geumcheon-gu, Seoul, Republic of Korea

**Factory.** 246 Gogol-gil, Deogyang-gu, Goyang-si, Gyeonggi-do, Republic of Korea

**Tel.** (+82)2038-0008

**Email.** sales@kscparts.com

# KOREX FORKLIFT

## DESIEL SERIES

1.5T | 2.5T | 3T | 5T | 7T | 10T Korex Diesel Foklift Series



# DIESEL FORKLIFT

KFX15D-E3 | KFX25D-E3 | KFX30D-E3 | KFX50D-E1 | KFX70D-E1 | KFX100D-E1

- Robust and Reliable Diesel Engine
- Ergonomically design
- Excellent Cooling System and Heat Releasing System



## DIESEL ENGINES SPECIFICATION

56KW(75HP)@3000RPM/ 108 N.M @2000RPM



Model	Unit	ISUZU C240
Type	-	4 cylinders inline, water-cooling, 4 stroke
Displacement	L	2.4 L
Rated Power	KW@rpm	56KW(75 HP)@3000rpm
Idle Speed	rpm	750 rpm
Peak Torque	Nm@rpm	108 N.m @2000rpm

# DIESEL FORKLIFT

KOREX FORKLIFT 1.5T | 2.5T | 3T | 5T | 7T | 10T



**Air Cleaner**

The air filter is readily accessible for cleaning or replacement.



**Engine Hood**

Secure your engine bay and fasten the vehicle hood not to be lifted.



**Fuel Cap**

Manufactured from durable, made proper sealing and venting.



**Easy Oil Check**

Secure your engine bay and fasten the vehicle hood not to be lifted.



**Switch and buzzer**

Hazard lights switch and reverse buzzer.



**Strong Overhead Guard**

Excellent all-around visibility and reduces potential danger.

# DIESEL FORKLIFT

KFX15D-E3 | KFX25D-E3 | KFX30D-E3 | KFX50D-E1 | KFX70D-E1 | KFX100D-E1



**OPTION: Back camera**  
At the same time as the engine starts, the monitor displays a rear situation and is safe while driving.



**Excellent Visibility for Safe Operation**  
Optimized lift cylinder arrangement provides a wide field of view.



**Parking Brake**  
Toggle type parking brake requires less effort from the operator to set.



**Lower Entrance Height**  
The lower entrance height ensures easy and safe access for the operator.



**Superior Comfort Design**  
The suspension cab and seat design reduces travel vibration by 30%.

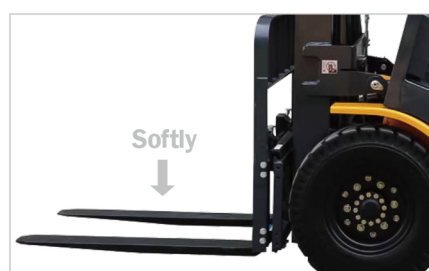

**Fork Safety Features**  
The down-safety valve prevents forks from dropping down in case of sudden damage to hydraulic line.

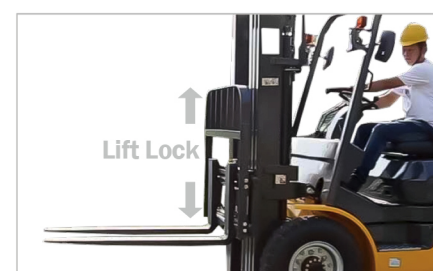

**OPS Operator Presence Sensor(Optional)**  
This comprehensive safety system includes a seal-actuated power.

# DIESEL FORKLIFT

KOREX FORKLIFT 1.5T | 2.5T | 3T | 5T | 7T | 10T

- Excellent safety and strong durability
- Products Working range

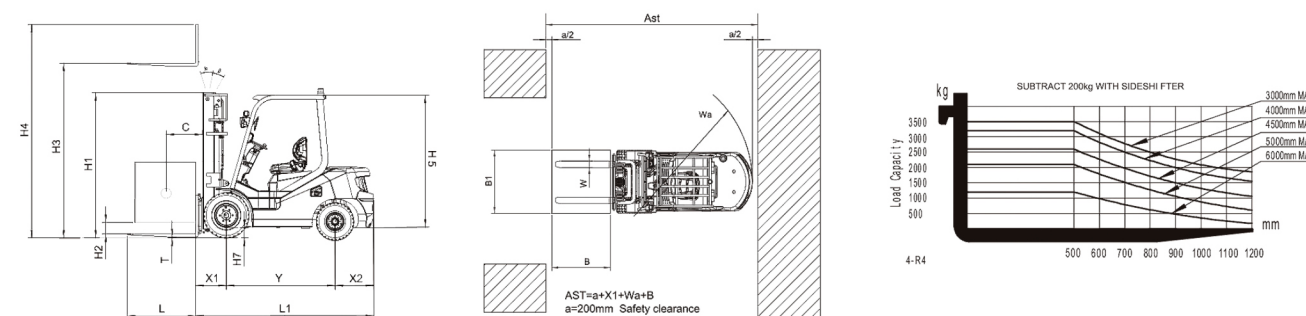

## SPECIFICATION

1.5T | 2.5T | 3T | 5T | 7T | 10T

Model	Unit	KFX15D-E3	KFX25D-E3	KFX25D-E3	KFX30D-E3	KFX50D-E1	KFX70D-E1	KFX100D-E1
Power Type	-	Diesel	Diesel	Diesel	Diesel	Diesel	Diesel	Diesel
Engine	-	Isuzu C240	Isuzu C240	Yanmar 4TNE98	Isuzu C240	ISUZU 6BG1	ISUZU 6BG1	ISUZU 6BG1
Rated Load Capacity	kg(ton)	1,500(1.5)	2,500(2.5)	2,500(2.5)	3,000(3.0)	5,000(5.0)	7,000(7.0)	10,000(10.0)
Load Center	mm	500	500	500	500	600	600	600
max lifting height	mm	3,000	3,000	3,230	3,000	3,000	3,000	3,000
Forks	mm	920	1,070	1,050	1,070	1,220	1,220	1,220
Tires	Front/Rear	-	-	4/2	-	-	-	-
	Size(Front)	-	-	7.00 x 15-12	-	-	-	-
Overall dimensions (without Fork)	L	mm	2,285	2,660	2,660	2,700	3,510	3,590
	W	mm	1,082	1,150	1,150	1,225	1,995	2,165
	H	mm	2,160	2,215	2,215	2,235	2,415	2,540

## ATTACHMENT ANNOUNCEMENT

